

SURGICAL TECHNIQUE GUIDE

ANTERIOR SPINE TRUSS SYSTEM

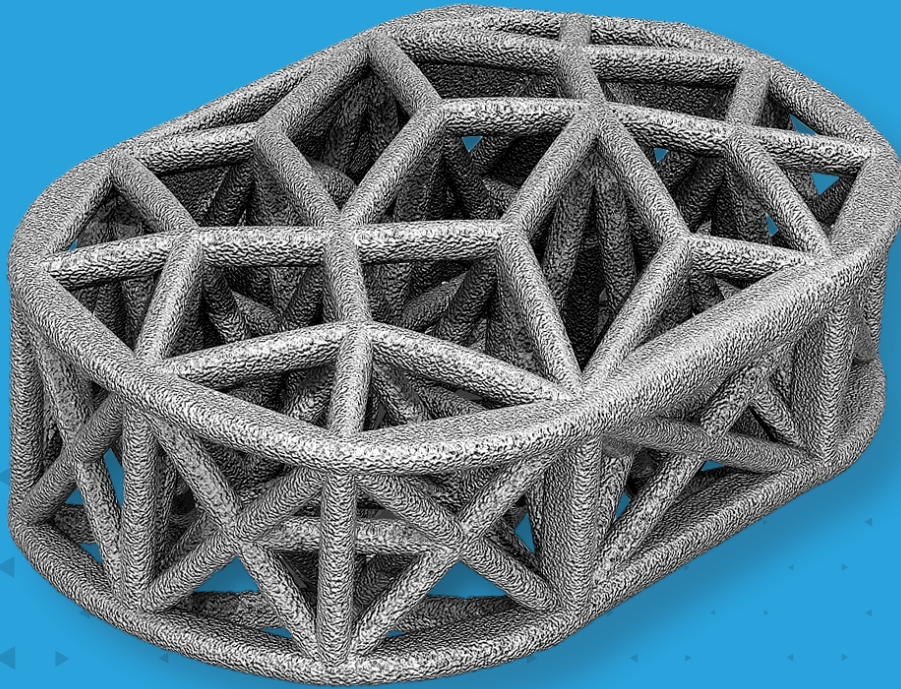



TABLE OF CONTENTS

TRUSS IMPLANT TECHNOLOGY™ _____	3
IMPLANT OVERVIEW _____	4
SURGICAL PROCEDURE _____	5
INSTRUMENT CATALOG _____	11
IMPLANT CATALOG _____	16

Federal law (USA) restricts these devices to sales by or on the order of a physician. Proper surgical procedure and technique are the responsibility of the medical professional. The following guidelines are furnished for information purposes only. Each surgeon must evaluate the appropriateness of the procedure based on his or her medical training and experience. Prior to use of the system, the surgeon should refer to the product's Instructions For Use (IFU) for complete warnings, precautions, indications, contraindications and adverse effects. IFUs are available by contacting 4WEB® at +1(800) 285-7090.

TRUSS IMPLANT TECHNOLOGY™



Novel Truss Implant Technology™ provides a Snow Shoe Interface that distributes load across the endplate which minimizes point loading and reduces the risk of subsidence.¹



Hierarchical surface roughness spans from the macro to nano scale. These surface features have been shown to stimulate increased gene expression of certain osteogenic markers when compared to other interbody surfaces and materials.^{2,3}



Open architecture design allows for greater graft volume and bone growth throughout the entire construct.¹

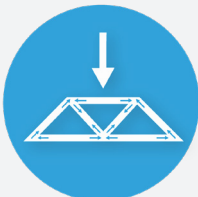

Distribution of load through the implant struts delivers strain to adjacent cellular material which stimulates a mechanobiologic response.²



Truss Implant design provides maximum strength with a minimal amount of material, which limits imaging artifacts.

¹ Data on file

² Lee et al., ORS, 2023 Annual Meeting, Dallas, TX

³ Rowe et al., SMISS, Annual Forum '19, p.52

ASTS OVERVIEW



The Anterior Spine Truss System (ASTS) contains three footprints in a variety of heights and lordotic angles to accommodate the patient's anatomy. It is not intended to be used as a stand-alone device and must be used with supplemental fixation. The ASTS implants are provided sterile.

Sizers and instruments are provided non-sterile and require sterilization prior to use.

INDICATIONS

The Anterior Spine Truss System (ASTS) Interbody Fusion Device is indicated for use in skeletally mature patients with Degenerative Disc Disease (DDD) at one or two contiguous levels from L2-S1. DDD is defined as discogenic back pain with degeneration of the disc confirmed by patient history and radiographic studies. Patients should have received 6 months of non-operative treatment prior to treatment with the devices. The device must be used with supplemental fixation and must be used with autograft and/or allogenic bone graft comprised of cancellous and/or corticocancellous bone graft. These DDD patients may also have up to Grade I spondylolisthesis or retrolisthesis at the involved level(s).

CONTRAINDICATIONS

The ASTS Interbody Fusion Device should not be implanted in patients with:

- An active infection at the operative site or other active systemic infections
- Tumor involvement at the operative site
- Prior fusion at the level(s) to be treated
- Known sensitivity to the material

WARNINGS AND PRECAUTIONS

See package insert for warnings, precautions, adverse effects, and other essential product information. Before using the ASTS Instrumentation, verify:

- Instruments have maintained design integrity; and,
- Proper size configurations are available.

For Instructions for Cleaning, Sterilization, Inspection and Maintenance, refer to IFU-ASTS-05 or OUS-IFU-ASTS-03.



► PRE-OPERATIVE PLANNING

Pre-operative planning with radiographs and other advanced imaging modalities can be helpful in estimating the appropriately sized implants with the goal of restoring disc height and fractional lordosis.

Determine the surgical approach based on the surgeon's preference (straight anterior or anterolateral). Implants and sizers are equipped with straight and offset instrument orientations.

Note: Implants and sizers utilize the same inserter.

► PATIENT POSITIONING

Place the patient in the supine position on the operating table with the lumbar spine in neutral to slight extension (Fig. 1).

Fluoroscopy can be utilized to aid with patient positioning.

Note: At times you may want to break the table in order to gain better access to the operative level(s), particularly when treating L5/S1.

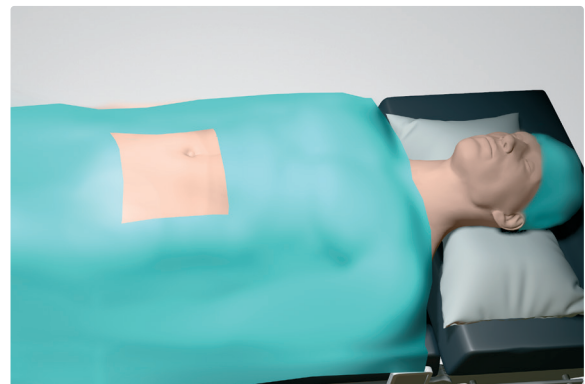

Figure 1



▶ ACCESS AND EXPOSURE

Locate the correct operative level under fluoroscopic guidance. A lower abdominal transverse incision, left vertical paramedian incision, or other appropriate incision is made depending on the exposure necessary to access the operative level(s) (Fig. 2).

Once the operative level(s) have been exposed, confirm the centerline of the affected level(s) with fluoroscopic imaging.

Note: Any bone removed during access and exposure may be used for autologous graft packing.

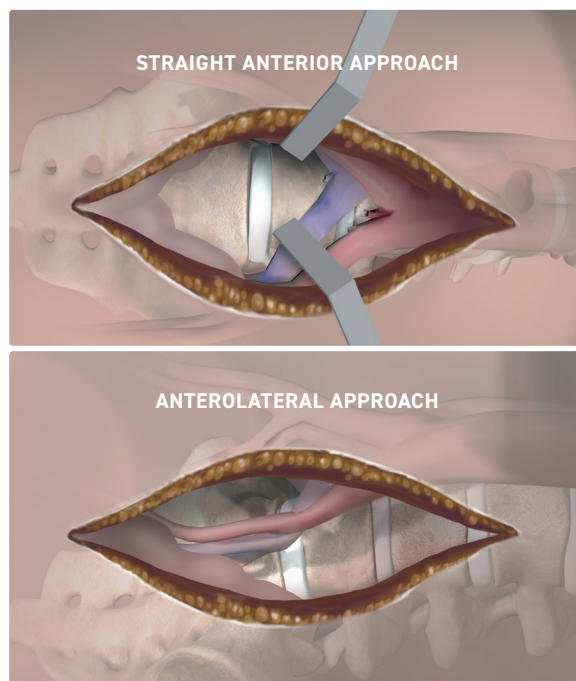

Figure 2

▶ DISCECTOMY AND ENDPLATE PREPARATION

Perform an annulotomy and subsequent anterior lumbar discectomy within the constraints of the operative window (Fig. 3).

Remove the superficial layers of the cartilaginous endplates down to bleeding bone while trying to avoid compromising the integrity of the bony endplates.

Additional distraction may be applied as desired to increase visualization.

Note: Appropriate cleaning of the endplates is important to provide blood flow to the autologous bone packed inside the implant. Excessive cleaning, on the other hand, can weaken the endplates.

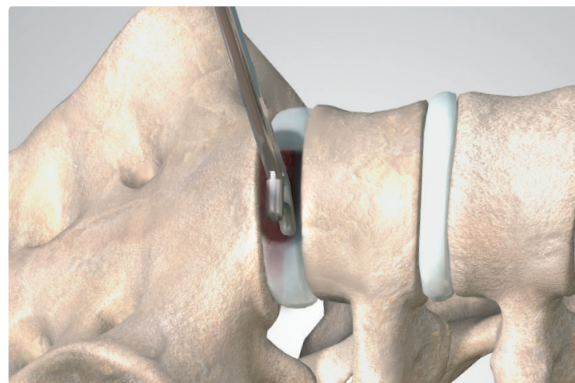

Figure 3



► IMPLANT SIZING

Select the appropriate sizer by footprint, height and lordotic angle, and attach it to the inserter. Ensure the prongs are fully seated and no threads are visible.

Be careful not to over-tighten.

Footprint, height, and lordotic angle measurements are clearly marked on the anterior face of the sizers.

Carefully impact the sizer into the disc space (Fig. 4). Check the correct fit of the sizer with the aid of fluoroscopy and palpation.

If the sizer is too loose or too tight, try the next larger/smaller size until a secure fit is achieved.

Remove the sizer from the prepared disc space and select the corresponding implant.

Note: Although over distraction of the disc space is to be avoided, the largest implant that can be safely implanted in the disc space is generally the optimal implant size. Maximizing the implant surface with the vertebral endplates and providing an appropriate amount of preload through disc space distraction will help to create a stable environment conducive to new bone formation.

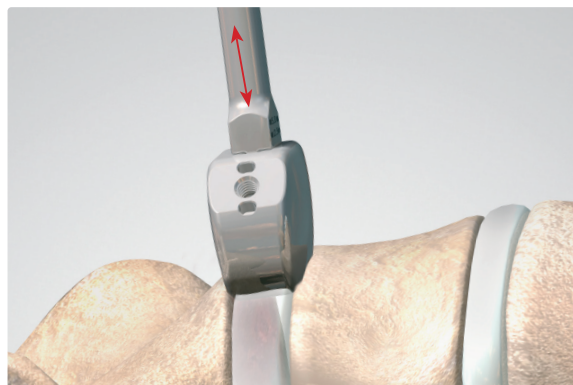

Figure 4



▶ IMPLANT PREPARATION

Attaching Implant Inserter:

ASTS implants are provided in a sterile package. Select the implant that corresponds to the appropriate size. Open the implant package using proper sterile technique.

Attach the implant to the inserter (Fig. 5). Ensure the prongs are fully seated and no threads are visible.

Be careful not to over-tighten.

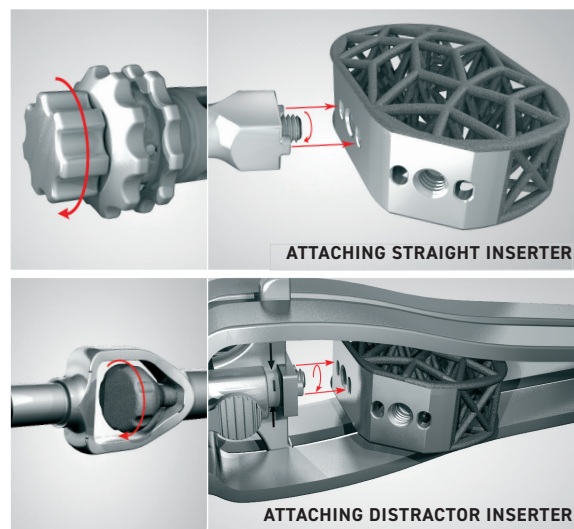

Figure 5

Packing Implant:

Pack the implant with autologous and/or allogenic bone graft. For best results, cut or morselize the autologous bone into 1–2mm sized particles. Place the morselized bone into the top or bottom web structure (top and bottom are interchangeable). In a downward, circular motion, massage the bone particles into the implant (Fig. 6).

Once packing has been completed through the top web structure, turn the implant over and repeat the placement of bone into the bottom web structure. Pack autologous bone into the implant as appropriate.

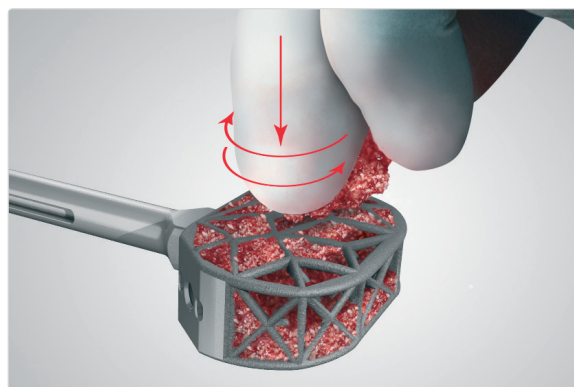

Figure 6



► IMPLANT INSERTION

Introduce the implant into the prepared intervertebral space and tap it into place with a mallet (Fig. 7). Confirm the proper placement of the implant using fluoroscopy.

Once the implant is in the proper position, disengage and remove the inserter.

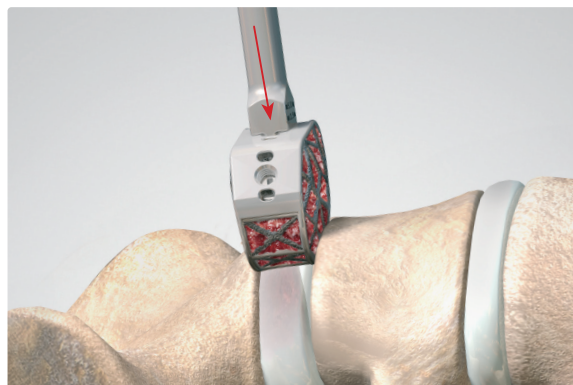

Figure 7

Distractor Inserter:

Introduce the Distractor Inserter into the prepared intervertebral space (Fig. 8). Gradually rotate the T-handle clockwise to advance the implant. The keel on the instrument can be adjusted to rest the implant at 0, 2, and 4mm recessed from the anterior margin. Confirm the proper placement of the implant using fluoroscopy.

Once the implant is in the proper position, disengage and remove the Distractor Inserter.

Implant Positioning:

If the implant needs to be positioned further into the prepared space, gently tap the implant with the tamp provided in the instrument tray.

Verify final placement of the implant with fluoroscopic imaging.

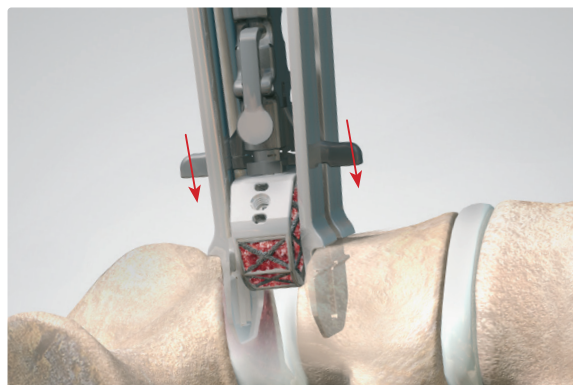

Figure 8



► IMPLANT REMOVAL

If implant removal is required, the intervertebral space should be distracted in the same manner as for implant placement. Once distracted, the implant may be removed by using the insertion tool (Fig. 9).

The implant should be disengaged from the superior and inferior endplates with the surgeon's preferred technique. The surgeon should apply slight back-pressure in order to remove the implant.

If greater force is required, use the slap hammer provided in the instrument tray to remove the implant (Fig. 10).

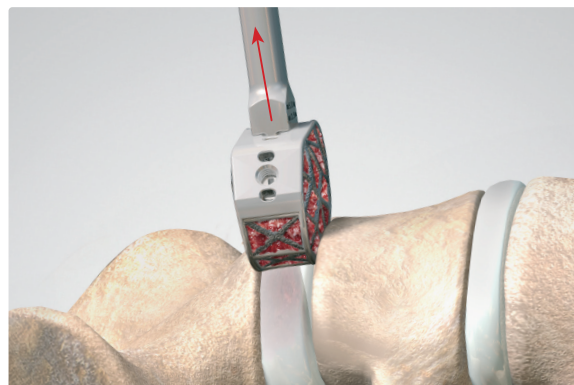

Figure 9

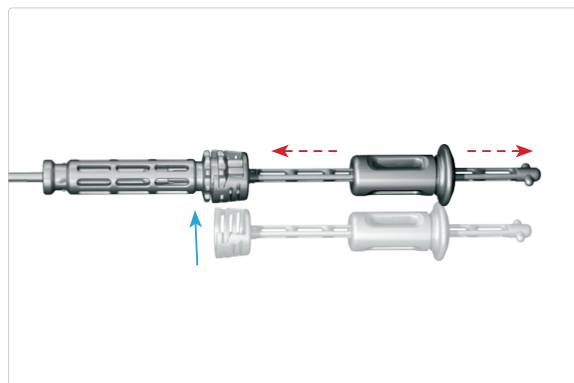

Figure 10

INSTRUMENT CATALOG



PART NUMBER	DESCRIPTION
711-1803-0	#3 STRAIGHT RING CURETTE



711-1803-1	#4 STRAIGHT RING CURETTE
------------	--------------------------



710-1804-1	#3 ANGLED RING CURETTE
------------	------------------------



710-1804-0	#4 ANGLED RING CURETTE
------------	------------------------



720-1834-0	3/4 INCH (0.75") COBB ELEVATOR
------------	--------------------------------





PART NUMBER	DESCRIPTION
720-1810-0	1 INCH (1.0") COBB ELEVATOR



763-1808-0C	STRAIGHT TAMP
-------------	---------------

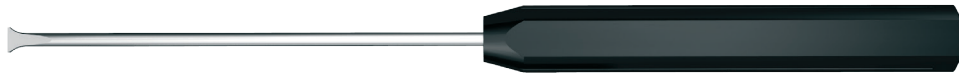

765-1812-0C	SINGLE-SIDED STRAIGHT RASP
-------------	----------------------------



873-1304-0	4MM STRAIGHT RONGEUR
------------	----------------------





PART NUMBER	DESCRIPTION
873-1304-1	4MM UP RONGEUR



830-1204-0	4MM KERRISON RONGEUR
------------	----------------------

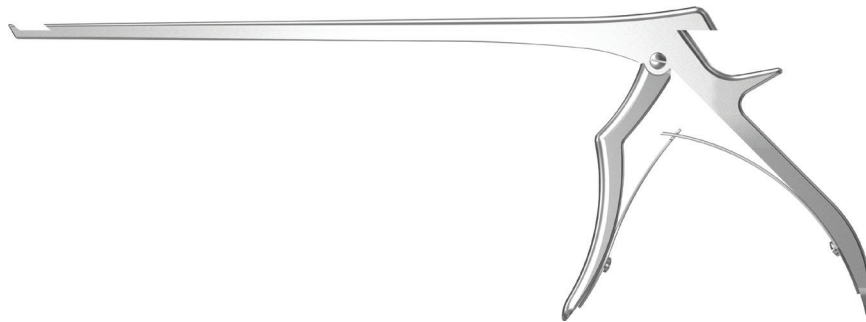

873-1412-0	12MM DOUBLE ACTION RONGEUR
------------	----------------------------

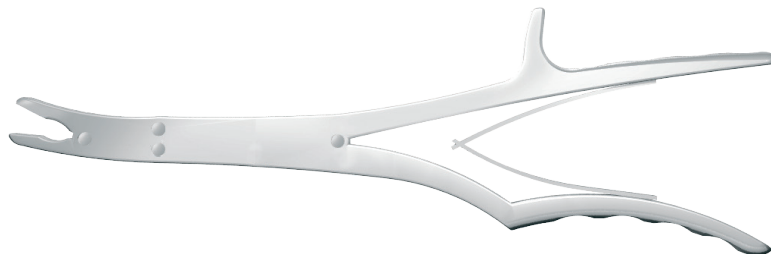



PART NUMBER	DESCRIPTION
ASTS-000004	DISTRACTOR INSERTER



ASTS-000007	STRAIGHT INSERTER
-------------	-------------------



ASTS-000050	SLAP HAMMER
-------------	-------------

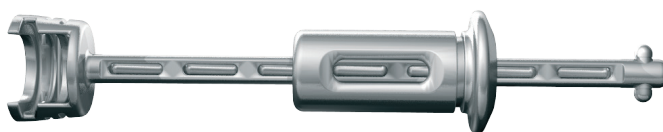

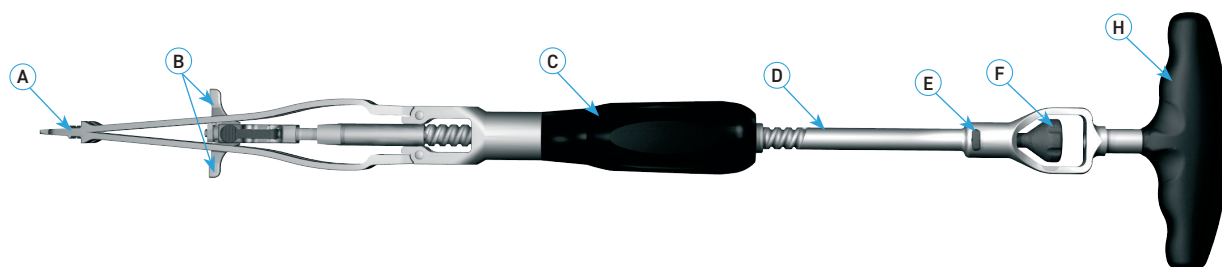

The Distractor Inserter is comprised of the following parts:

- A) Shims
- B) Keel
- C) Inserter body
- D) Threaded shaft
- E) Threaded shaft quick-release button
- F) Implant locking knob
- G) Inner shaft
- H) T-handle

Instrument Disassembly:

1. Press the quick-release button (E located below the implant locking knob (Fig. 11) and pull the knob towards the T-handle to release and remove the locking knob from the inner shaft (Fig. 12).
2. Manually feed the inner shaft (G) through the cannulated T-handle out the proximal end of the instrument (Fig. 13).
3. Remove the keel (B) from the distal end of the threaded shaft by splaying the shims (Fig. 14).

Instrument Reassembly:

To reassemble follow the disassembly instructions in reverse order.

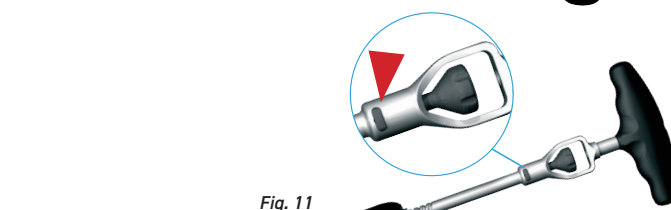

Fig. 11

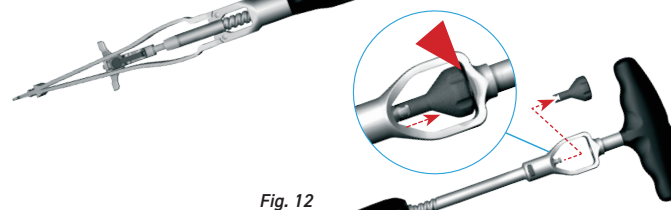

Fig. 12

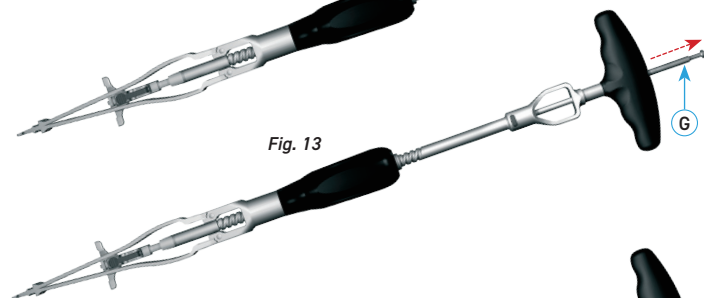

Fig. 13

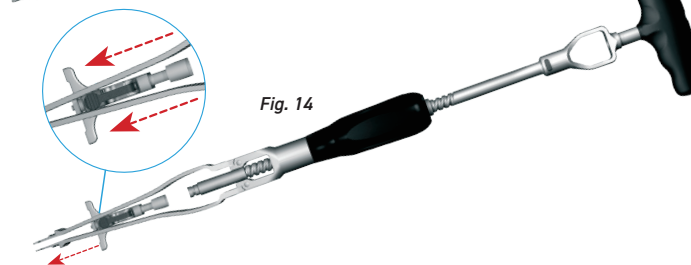
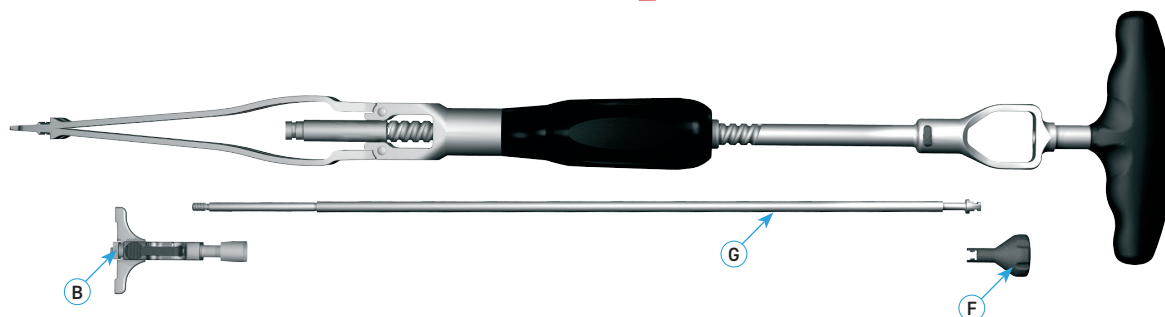
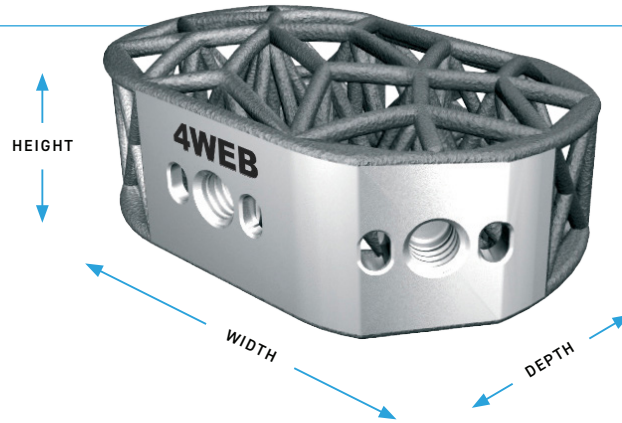

Fig. 14



IMPLANT CATALOG



INTERBODY DEVICES

CATALOG NUMBER	FOOTPRINT D x W x H	LORDOSIS
ASTS-SM0608-SP	21 x 32 x 8mm	6°
ASTS-SM0610-SP	21 x 32 x 10mm	6°
ASTS-SM0612-SP	21 x 32 x 12mm	6°
ASTS-SM0614-SP	21 x 32 x 14mm	6°
ASTS-SM0616-SP	21 x 32 x 16mm	6°
ASTS-MD0608-SP	24 x 36 x 8mm	6°
ASTS-MD0610-SP	24 x 36 x 10mm	6°
ASTS-MD0612-SP	24 x 36 x 12mm	6°
ASTS-MD0614-SP	24 x 36 x 14mm	6°
ASTS-MD0616-SP	24 x 36 x 16mm	6°
ASTS-LG0608-SP	27 x 40 x 8mm	6°
ASTS-LG0610-SP	27 x 40 x 10mm	6°
ASTS-LG0612-SP	27 x 40 x 12mm	6°
ASTS-LG0614-SP	27 x 40 x 14mm	6°
ASTS-LG0616-SP	27 x 40 x 16mm	6°
ASTS-SM1208-SP	21 x 32 x 8mm	12°



CATALOG NUMBER	FOOTPRINT D x W x H	LORDOSIS
ASTS-SM1210-SP	21 x 32 x 10mm	12°
ASTS-SM1212-SP	21 x 32 x 12mm	12°
ASTS-SM1214-SP	21 x 32 x 14mm	12°
ASTS-SM1216-SP	21 x 32 x 16mm	12°
ASTS-MD1208-SP	24 x 36 x 8mm	12°
ASTS-MD1210-SP	24 x 36 x 10mm	12°
ASTS-MD1212-SP	24 x 36 x 12mm	12°
ASTS-MD1214-SP	24 x 36 x 14mm	12°
ASTS-MD1216-SP	24 x 36 x 16mm	12°
ASTS-LG1208-SP	27 x 40 x 8mm	12°
ASTS-LG1210-SP	27 x 40 x 10mm	12°
ASTS-LG1212-SP	27 x 40 x 12mm	12°
ASTS-LG1214-SP	27 x 40 x 14mm	12°
ASTS-LG1216-SP	27 x 40 x 16mm	12°
ASTS-MD1610-SP	24 x 36 x 10mm	16°
ASTS-MD1612-SP	24 x 36 x 12mm	16°
ASTS-MD1614-SP	24 x 36 x 14mm	16°
ASTS-MD1616-SP	24 x 36 x 16mm	16°
ASTS-LG1610-SP	27 x 40 x 10mm	16°
ASTS-LG1612-SP	27 x 40 x 12mm	16°



CATALOG NUMBER	FOOTPRINT D x W x H	LORDOSIS
ASTS-LG1614-SP	27 x 40 x 14mm	16°
ASTS-LG1616-SP	27 x 40 x 16mm	16°
ASTS-MD2012-SP	24 x 36 x 12mm	20°
ASTS-MD2014-SP	24 x 36 x 14mm	20°
ASTS-MD2016-SP	24 x 36 x 16mm	20°
ASTS-MD2018-SP	24 x 36 x 18mm	20°
ASTS-LG2012-SP	27 x 40 x 12mm	20°
ASTS-LG2014-SP	27 x 40 x 14mm	20°
ASTS-LG2016-SP	27 x 40 x 16mm	20°
ASTS-LG2018-SP	27 x 40 x 18mm	20°
ASTS-MD2514-SP	24 x 36 x 14mm	25°
ASTS-MD2516-SP	24 x 36 x 16mm	25°
ASTS-MD2518-SP	24 x 36 x 18mm	25°
ASTS-LG2514-SP	27 x 40 x 14mm	25°
ASTS-LG2516-SP	27 x 40 x 16mm	25°
ASTS-LG2518-SP	27 x 40 x 18mm	25°



2801 NETWORK BLVD. SUITE 620
FRISCO, TX 75034
4WEBMEDICAL.COM
INFO@4WEBMEDICAL.COM
800.285.7090
ST-ASTS-01 | REV F 01-2026